



## Structural Criteria for Residential Rooftop Solar Energy Installations

### Use of this document

This toolkit document includes a one-page list of structural criteria for over-the-counter approval, as well as attached tables and figures that supplement the criteria and explain their use.

This document applies to flush-mounted solar arrays installed on the roofs of wood-framed one- and two- family dwellings. “Flush-mounted” means the modules are installed parallel to, and relatively close to, the roof surface (see the “Solar Array Check” section of the Structural Criteria for specific qualifying requirements). This list is intended to be a simple pre-installation check to gain reasonable assurance that the design of the solar array complies with the structural provisions of the 2013 California Building Code (CBC) and 2013 California Residential Code (CRC). It is not intended to provide post-installation inspection criteria.

### Regional and Site Assumptions

This document is based on the following regional and site assumptions:

- The dwelling is located in a ZERO snow load area (see Map 1).
- The dwelling is not in Wind Exposure D (within 200 yards of the ocean or a large coastal bay).
- If in Wind Exposure B (urban, suburban or wooded areas), the dwelling may be located:
  - in a Special Wind Region (see Map 2) with design wind speeds between 110 and 130 mph.
  - on a tall hill, provided average slope is no steeper than 15%.
- If in Wind Exposure C (within 500 yards of large open fields or grasslands), the dwelling is:
  - in a standard 110 mph design wind speed region.
  - not on a hill with a grade steeper than 5%.

### The Structural Toolkit and CRC Wind Speeds

The 2013 CRC contains an inconsistency related to wind speeds. Despite referencing ASCE 7-10 as its standard, the 2013 CRC’s text and tables use outdated ASCE 7-05 wind speeds. Under the old ASCE 7-05/CBC 2010, the basic design wind speed in most regions of the state was 85 mph (max. 3 second gust in 50 years). Under ASCE 7-10/CBC 2013, the design wind speed has increased to 110 mph (max. 3 second gust in 700 years). Despite the different definitions of wind speed, design wind pressures remain essentially unchanged.

Because the toolkit’s structural document is intended to be forward looking, all wind speeds in the toolkit document are based on the ASCE 7-10. This is clearly stated in the caption to the state wind speed map, and in the Table 1 footnotes. This anticipates an obvious and expected correction to the CRC; otherwise the toolkit would become immediately outdated when the CRC is amended to change the base design wind speed from 85 mph to 110 mph.

2013 CRC text (ASCE 7-05) wind speeds equivalent to the 2013 CRC and CBC Reference Standard (ASCE 7-10) are shown below. See ASCE 7-10 Table C26.5-6 for additional information.

2013 CRC text	2013 CRC and CBC Referenced Standard
<u>ASCE 7-05</u>	<u>ASCE 7-10</u>
85 mph	110 mph

## Structural Technical Appendix

This toolkit document is supported by a Structural Technical Appendix that describes the technical analysis behind these criteria, which are based on structural engineering principles and the California Building and Residential Codes. The Technical Appendix also provides some additional guidance to address non-conforming items, such as when an anchor layout is not based on a solar support component manufacturer's guidelines, or when a coastal site is located within 200 yards of the ocean (Exposure D). This document can be found at:

[http://www.opr.ca.gov/docs/Solar\\_Structural\\_Technical\\_Appendix.pdf](http://www.opr.ca.gov/docs/Solar_Structural_Technical_Appendix.pdf)

## Probability of Code Compliance

The Structural Technical Appendix includes a section that examines the probabilities associated with the assumptions behind Table 1 that allows six feet cross-slope anchor spacing in some circumstances. That statistical analysis estimates that the probability of code noncompliance for six feet anchor spacing is only 2 in a thousand installations (0.2%). Note that probability of structural failure is orders of magnitude lower than the probability of code *noncompliance*.

# STRUCTURAL CRITERIA FOR RESIDENTIAL FLUSH-MOUNTED SOLAR ARRAYS

## 1. ROOF CHECKS

- A. Visual Review/Contractor's Site Audit of Existing Conditions:
- 1) Is the roof a single roof without a reroof overlay?  Y  N
  - 2) Does the roof structure appear structurally sound, without signs of alterations or significant structural deterioration or sagging, as illustrated in Figure 1?  Y  N
- B. Roof Structure Data:
- 1) Measured roof slope (e.g. 6:12): \_\_\_\_\_:12
  - 2) Measured rafter spacing (center-to-center): \_\_\_\_\_ inch
  - 3) Type of roof framing (rafter or manufactured truss):  Rafter  Truss
  - 4) Measured rafter size (e.g. 13/4 x 33/4, not 2x4): \_\_\_\_\_ x \_\_\_\_\_ inch
  - 5) Measured rafter horizontal span (see Figure 4): \_\_\_\_\_' - \_\_\_\_\_"ft-in
  - 6) Horizontal rafter span per Table 2: \_\_\_\_\_' - \_\_\_\_\_"ft-in
  - 7) Is measured horizontal rafter span less than Table 2 span?  Y  N  Truss

## 2. SOLAR ARRAY CHECKS

- A. Flush-mounted Solar Array:
- 1) Is the plane of the modules (panels) parallel to the plane of the roof?  Y  N
  - 2) Is there a 2" to 10" gap between underside of module and the roof surface?  Y  N
  - 3) Modules do not overhang any roof edges (ridges, hips, gable ends, eaves)?  Y  N
- B. Do the modules plus support components weigh no more than:  
4 psf for photovoltaic arrays or 5 psf for solar thermal arrays?  Y  N
- C. Does the array cover no more than half of the total roof area (all roof planes)?  Y  N
- D. Are solar support component manufacturer's project-specific completed worksheets, tables with relevant cells circled, or web-based calculator results attached?  Y  N
- E. Is a roof plan of the module and anchor layout attached? (see Figure 2)  Y  N
- F. Downward Load Check (Anchor Layout Check):
- 1) Proposed anchor horizontal spacing (see Figure 2): \_\_\_\_\_' - \_\_\_\_\_"ft-in
  - 2) Horizontal anchor spacing per Table 1: \_\_\_\_\_' - \_\_\_\_\_"ft-in
  - 3) Is proposed anchor horizontal spacing equal to or less than Table 1 spacing?  Y  N
- G. Wind Uplift Check (Anchor Fastener Check):
- 1) Anchor fastener data (see Figure 3):
    - a. Diameter of lag screw, hanger bolt or self-drilling screw: \_\_\_\_\_ inch
    - b. Embedment depth of rafter: \_\_\_\_\_ inch
    - c. Number of screws per anchor (typically one): \_\_\_\_\_
    - d. Are 5/16" diameter lag screws with 2.5" embedment into the rafter used, OR does the anchor fastener meet the manufacturer's guidelines?  Y  N

## 3. SUMMARY

- A. All items above are checked YES. No additional calculations are required.
- B. One or more items are checked NO. Attach project-specific drawings and calculations stamped and signed by a California-licensed civil or structural engineer.

Job Address: \_\_\_\_\_ Permit #: \_\_\_\_\_  
 Contractor/Installer: \_\_\_\_\_ License # & Class: \_\_\_\_\_  
 Signature: \_\_\_\_\_ Date: \_\_\_\_\_ Phone #: \_\_\_\_\_

Table 1. Maximum Horizontal Anchor Spacing				
Roof Slope		Rafter Spacing		
		16" o.c.	24" o.c.	32" o.c.
Photovoltaic Arrays (4 psf max)				
Flat to 6:12	0° to 26°	5'-4"	6'-0"	5'-4"
7:12 to 12:12	27° to 45°	1'-4"	2'-0"	2'-8"
13:12 to 24:12	46° to 63°	1'-4"	2'-0"	2'-8"
Solar Thermal Arrays (5 psf max)				
Flat to 6:12	0° to 26°	4'-0"	4'-0"	5'-4"
7:12 to 12:12	27° to 45°	1'-4"	2'-0"	2'-8"
13:12 to 24:12	46° to 63°	Calc. Req'd	Calc. Req'd	Calc. Req'd

*Solar support component manufacturer's guidelines may be relied upon to ensure the array above the roof is properly designed, but manufacturer's guidelines typically do NOT check to ensure that the roof itself can support the concentrated loads from the solar array. Table 1 assumes that the roof complied with the building code in effect at the time of construction, and places limits on anchor horizontal spacing to ensure that a roof structure is not overloaded under either downward loads or wind uplift loads. Note 4 below lists the basic assumptions upon which this table is based.*

Table 1 Notes:

1. Anchors are also known as “stand-offs,” “feet,” “mounts” or “points of attachment.” Horizontal anchor spacing is also known as “cross-slope” or “east-west” anchor spacing (see Figure 2).
2. If anchors are staggered from row-to-row going up the roof, the anchor spacing may be twice that shown above, but no greater than 6'-0”.
3. For manufactured plated wood trusses at slopes of flat to 6:12, the horizontal anchor spacing shall not exceed 4'-0” and anchors in adjacent rows shall be staggered.
4. This table is based on the following assumptions:
  - The roof structure conformed to building code requirements at the time it was built.
  - The attached list of criteria is met.
  - Mean roof height is not greater than 40 feet.
  - Roof sheathing is at least 7/16” thick oriented strand board or plywood. 1x skip sheathing is acceptable.
  - If the dwelling is in Wind Exposure B (typical urban, suburban or wooded areas farther than 500 yards from large open fields), no more than one of the following conditions apply:
    - The dwelling is located in a Special Wind Region with design wind speed between 115 and 130 mph per ASCE 7-10.
    - The dwelling is located on the top half of a tall hill, provided average slope is less than 15%.
  - If the dwelling is in Wind Exposure C (within 500 yards of large open fields or grasslands), all of the following conditions apply.
    - Design wind speed is 110 mph or less (not in a Special Wind Region).
    - The dwelling is not located on the top half of a tall hill.
  - The solar array displaces roof live loads (temporary construction loads) that the roof was originally designed to carry.
  - The Structural Technical Appendix provides additional information about analysis assumptions.

Table 2. Roof Rafter Maximum Horizontal Span (feet - inches) <sup>1</sup>								
Assumed Vintage	Nominal Size	Actual Size	Non-Tile Roof <sup>2</sup>			Tile Roof <sup>3</sup>		
			Rafter Spacing					
			16" o.c.	24" o.c.	32" o.c.	16" o.c.	24" o.c.	32" o.c.
Post-1960	2x4	1½"x3½"	9'-10"	8'-0"	6'-6"	8'-6"	6'-11"	5'-6"
	2x6	1½"x5½"	14'-4"	11'-9"	9'-6"	12'-5"	10'-2"	8'-0"
	2x8	1½"x7¼"	18'-2"	14'-10"	12'-0"	15'-9"	12'-10"	10'-3"
Pre-1960	2x4	1¾"x3¾"	11'-3"	9'-9"	7'-9"	10'-3"	8'-6"	6'-9"
	2x6	1¾"x5¾"	17'-0"	14'-0"	11'-3"	14'-9"	12'-0"	9'-9"
	2x8	1¾"x7¾"	22'-3"	18'-0"	14'-6"	19'-0"	15'-6"	12'-6"

Beyond a visual review by the contractor checking for unusual sagging or deterioration, some CBOs may want additional assurance that the roof structure complies with structural building code requirements. Table 2 is an optional table some CBOs may elect to use to provide additional assurance by requiring a check of existing roof rafter spans, and supports optional criteria 1.B.5 and 1.B.6. For post-1960 construction, these span tables match the rafter span tables found in the 2013 California Building and Residential codes. For pre-1960 construction, the rafter span tables are based on structural calculations with lumber sizes and wood species and grade appropriate for older construction. Note 5 below lists the basic assumptions upon which this table is based.

Table 2 Notes:

1. See Figure 4 for definition of roof rafter maximum horizontal span.
2. "Non-tile Roof" = asphalt shingle, wood shingle and wood shake, with an assumed roof assembly weight of 10 psf.
3. "Tile Roof" = clay tile or cement tile, with an assumed roof assembly weight of 20 psf
4. Unaltered manufactured plated-wood trusses may be assumed to be code compliant and meet intent of Table 2.
5. This table is based on the following assumptions:
  - Span/deflection ratio is equal to or greater than 180.
  - For post-1960 construction, wood species and grade is Douglas Fir-Larch No. 2.
  - For pre-1960 construction, wood species and grade is Douglas Fir-Larch No. 1.
  - Other wood species and/or grade are also acceptable if allowable bending stress is equal or greater to that listed.

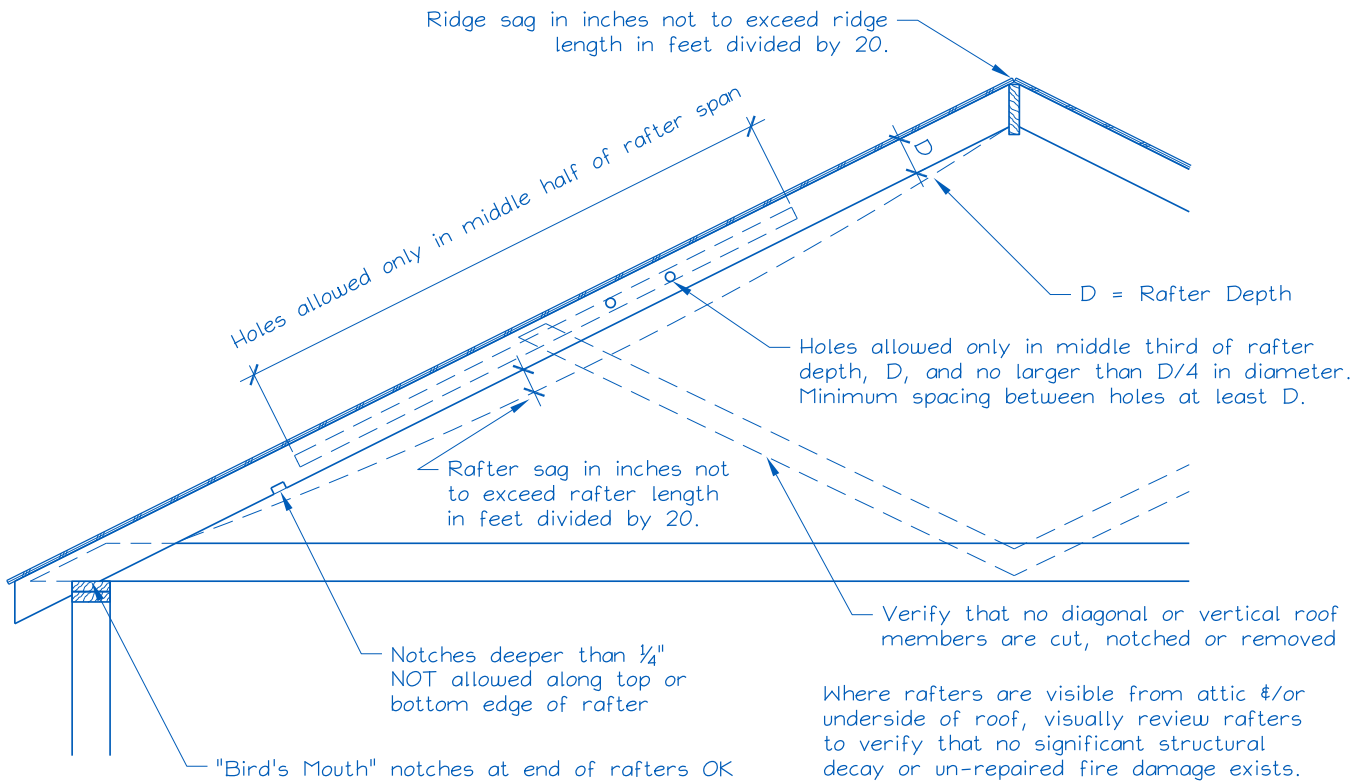
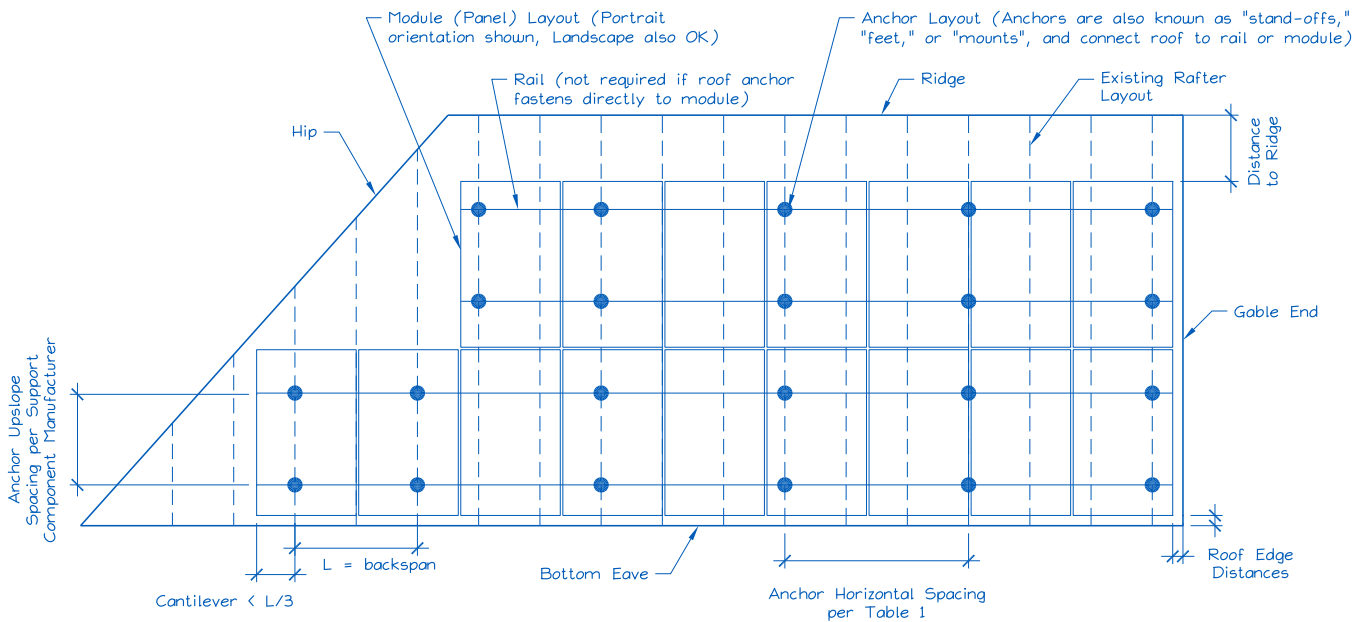

**Figure 1. Roof Visual Structural Review (Contractor's Site Audit) of Existing Conditions.**

The site auditor should verify the following:

1. No visually apparent disallowed rafter holes, notches and truss modifications as shown above.
2. No visually apparent structural decay or un-repaired fire damage.
3. Roof sag, measured in inches, is not more than the rafter or ridge beam length in feet divided by 20.

Rafters that fail the above criteria should not be used to support solar arrays unless they are first strengthened.



**Figure 2. Sample Solar Panel Array and Anchor Layout Diagram (Roof Plan).**

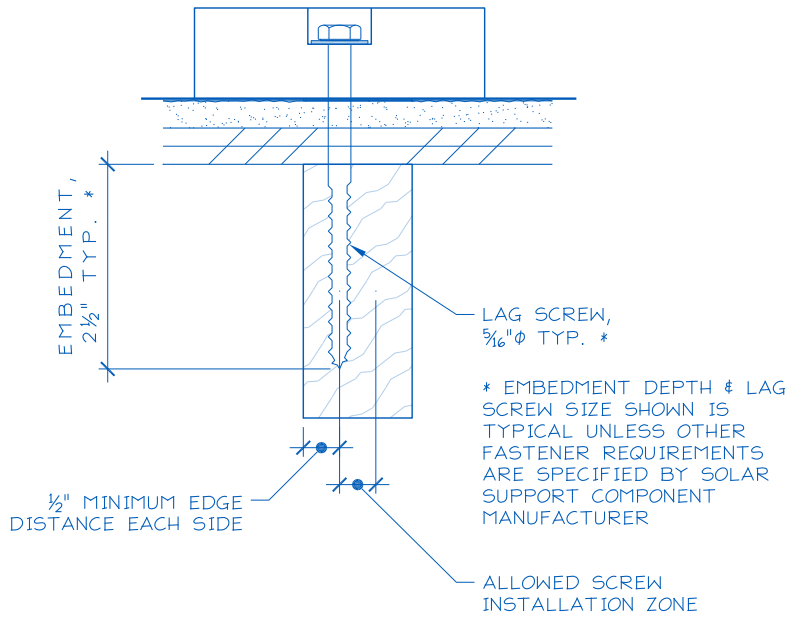

**Figure 3. Typical Anchor with Lag Screw Attachment.**

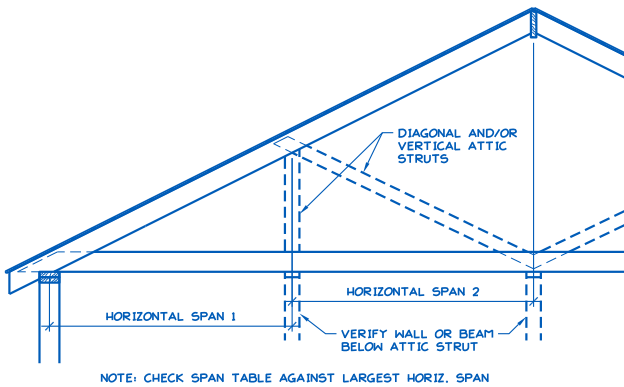

**C** STRUTS TO WALLS BELOW

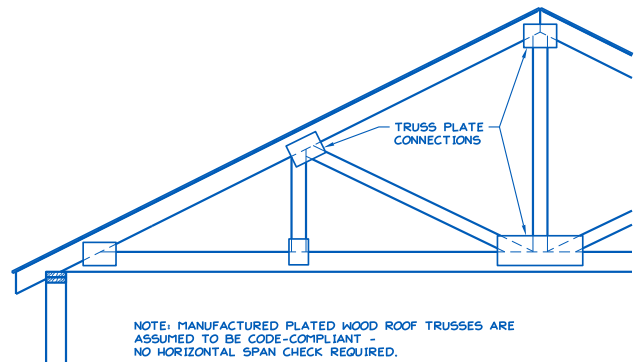

**D** MANUFACTURED PLATED WOOD ROOF TRUSS

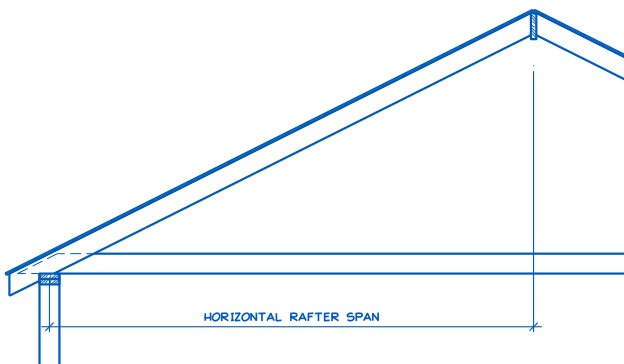

**A** SIMPLE ATTIC

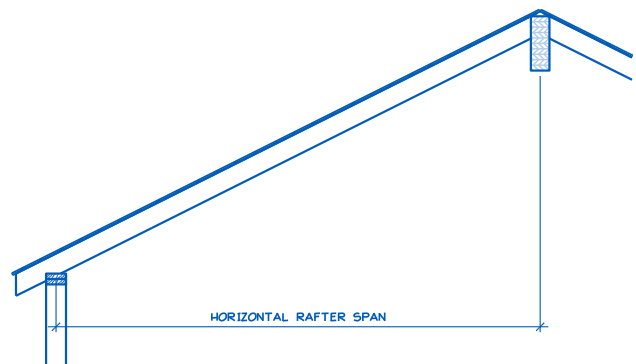

**B** CATHEDRAL CEILING

**Figure 4. Definition of Rafter Horizontal Span.**